

Fig.2
M 42

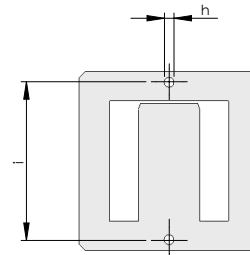
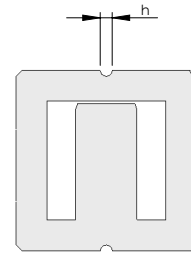

Fig.3
M 30



Nennmaß (mm)	Toleranz +/- 1/2 IT 12
Bereich	(mm)
≤ 3	+/- 0,050
> 3... 6	+/- 0,060
> 6... 10	+/- 0,075
> 10... 18	+/- 0,090
> 18... 30	+/- 0,105
> 30... 50	+/- 0,125
> 50... 80	+/- 0,150
> 80...120	+/- 0,175
> 120...180	+/- 0,200
> 180...250	+/- 0,230
> 250...315	+/- 0,260
> 315...400	+/- 0,285
> 400...500	+/- 0,315

M-Bleche nach DIN EN 60740-1 / M-laminations according to DIN EN 60740-1

Abmessungen / Dimensions Fig. 1 + 2 + 3

Typ	a	b	c	d	e	f	h	i	(k ₁)	m	r	t
	±1/2 IT 12	±1/2 IT 12	±1/2 IT 12	±1/2 IT 12	±1/2 IT 14		JS 14	±1/2 IT 12				
M 42	42	42	30	12	30	6	3,5	36	3	2	2	ca. 0,1
M 55	55	55	38	17	38	8,5	3,5	47	4	2,5	2,5	ca. 0,1
M 65	65	65	45	20	45	10	4,5	56	4,5	2,5	2,5	ca. 0,1
M 74	74	74	51	23	51	11,5	4,5	64	5	2,5	2,5	ca. 0,1
M 85	85	85	56	29	56	14,5	4,5	75	5	3	3	ca. 0,1
M 102	102	102	68	34	68	17	5,5	91	5,5	3	3	ca. 0,1

Gewicht / Weight kg/1.000	
0,5 mm	0,35 mm
4,6	3,2
8,5	5,8
11,8	8,1
15,5	10,6
21,9	15,0
31,0	21,3

Der Trennlufspalt am Mittelschenkel ist zur Minimierung der magnetischen Verluste und zur Optimierung der Verarbeitbarkeit als Mini-Lufspalt mit 0,1 mm ausgeführt. Auf Wunsch können auch andere Luftspalte geliefert werden.

The separating air gap located at the center leg is a mini-air gap of about 0,1 mm, which serves reducing magnetic losses and improving processing. On request, air gaps can vary according to customers needs.

Erich Grau GmbH
 Stanzwerk f. Elektrobleche
 Umlandstr. 3-7
 D-74372 Sersheim
 Tel.: +49 (0) 7042/8363-0
 Fax: +49 (0) 7042/8363-63
 Mail: info@grau-stanzwerk.de
 Web: www.grau-stanzwerk.de

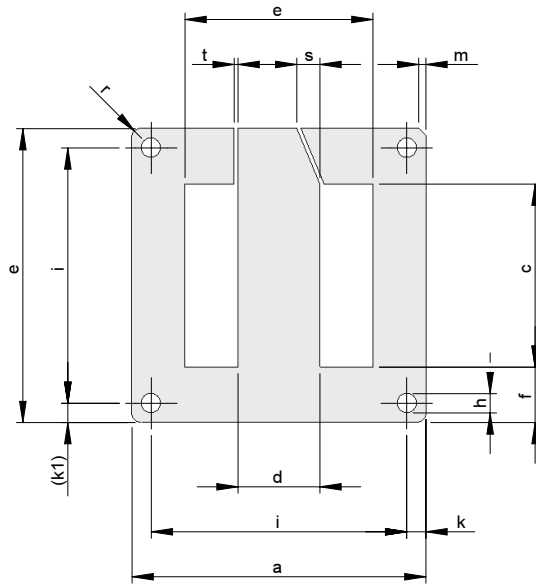

PM-Bleche / PM-laminations

Abmessungen / Dimensions

Typ	a	c	d	e	f	h	i	(k1)	m	r	s	t
PM 72	72	45	20	47	13,5	4,4	62	5	2	3	5,6	0,2
PM 82	82	51	23	53	15,5	4,4	72	5	2	3	7	0,2
PM 95	95	56	29	59	19,5	4,7	85	5	2	3	8,9	0,25
PM 114	114	68	34	71	23	5,4	102	6	3	4	10,5	0,25

Nennmaß (mm)	Toleranz +/- 1/2 IT 12
Bereich	(mm)
≤ 3	+/- 0,050
> 3... 6	+/- 0,060
> 6... 10	+/- 0,075
> 10... 18	+/- 0,090
> 18... 30	+/- 0,105
> 30... 50	+/- 0,125
> 50... 80	+/- 0,150
> 80...120	+/- 0,175
> 120...180	+/- 0,200
> 180...250	+/- 0,230
> 250...315	+/- 0,260
> 315...400	+/- 0,285
> 400...500	+/- 0,315

Gewicht / Weight kg/1.000	
0,5 mm	0,35 mm
15,0	10,3
19,7	13,5
27,9	19,2
39,9	27,4

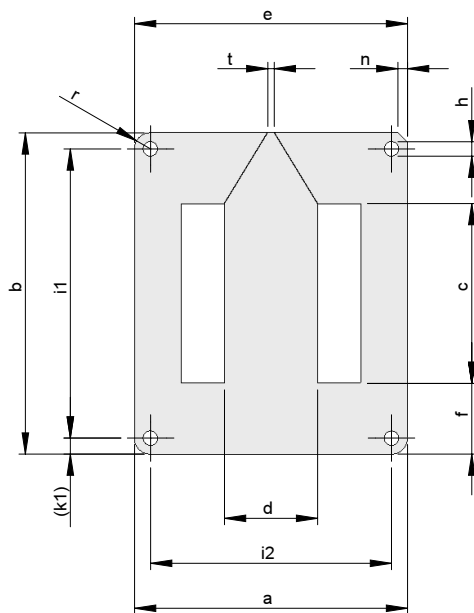

MD-Bleche Ausführung / MD-laminations

Abmessungen / Dimensions / Dimensions

Typ	a	b	c	d	e	f	h	i ₁	i ₂	(k1)	n	r	t
MD 85	85	100	56	29	56	22	4,5	90	75	5	3	5	2

Gewicht / Weight kg/1.000	
0,5 mm	0,35 mm
26,5	18,2